



AUTOMATIC PHASE CHANGER

■ MUHAMMAD AJMAL P.

In three-phase applications, if low voltage is available in any one or two phases, and you want your equipment to work on normal voltage, this circuit will solve your problem. However, a proper-rating fuse needs to be used in the input lines (R, Y and B) of each phase. The circuit provides correct voltage in the same power supply lines through relays from the other phase where correct voltage is available. Using it you can operate all your equipment even when correct voltage is available on a single phase in the

The mains power supply phase R is stepped down by transformer X1 to deliver 12V, 300 mA, which is rectified by diode D1 and filtered by capacitor C1 to produce the operating voltage for the operational amplifier (IC1). The voltage at inverting pin 2 of operational amplifier IC1 is taken from the voltage divider circuit of resistor R1 and preset resistor VR1. VR1 is used to set the reference voltage according to the requirement. The reference voltage at non-inverting pin 3 is fixed to 5.1V through zener diode ZD1.

Till the supply voltage available in phase R is in the range of 200V-230V,

As soon as phase-R voltage goes below 200V, the voltage at inverting pin 2 of IC1 goes below reference voltage of 5.1V, and its output goes low. As a result, transistor T1 conducts and relay RL1 energises and load L1 is disconnected from phase 'R' and connected to phase 'Y' through relay RL2.

Similarly, the auto phase-change of the remaining two phases, viz, phase 'Y' and phase 'B,' can be explained. Switch S1 is mains power 'on'/'off' switch.

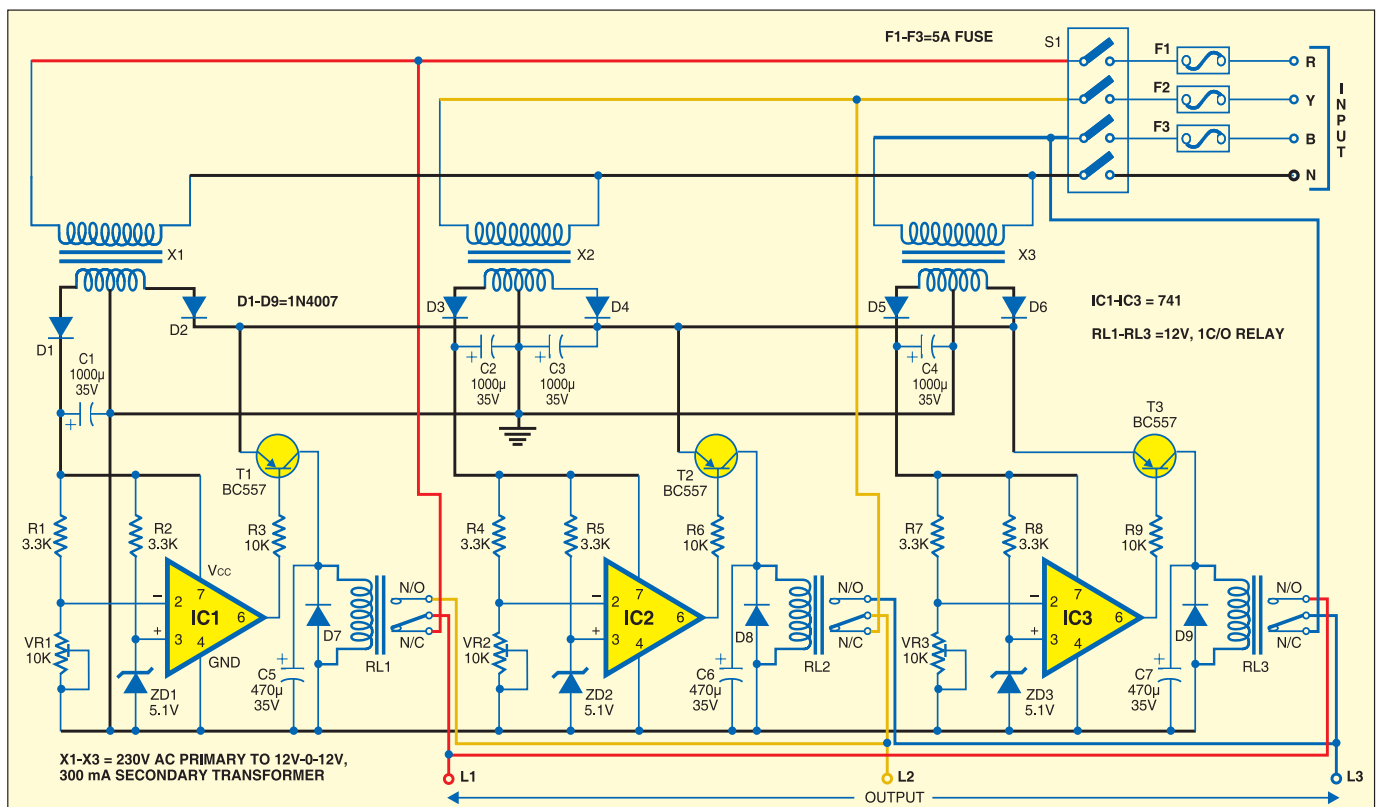

building.

The circuit is built around a transformer, comparator, transistor and relay. Three identical sets of this circuit, one each for three phases, are used. Let us now consider the working of the circuit connecting red cable (call it 'R' phase).

the voltage at inverting pin 2 of IC1 remains high, i.e., more than reference voltage of 5.1V, and its output pin 6 also remains high. As a result, transistor T1 does not conduct, relay RL1 remains de-energised and phase 'R' supplies power to load L1 via normally-closed (N/C) contact of relay RL1.

Use relay contacts of proper rating and fuses should be able to take-on the load when transferred from other phases. While wiring, assembly and installation of the circuit, make sure that you:

1. Use good-quality, multi-strand insulated copper wire suitable for your

current requirement.

2. Use good-quality relays with proper contact and current rating.

3. Mount the transformer(s) and relays on a suitable cabinet. Use a Tag Block (TB) for incoming/outgoing con-

nections from mains.

EFY Note: 1. During testing in the lab, we used a 12V, 200-ohm, single-phase changeover relay with 6A current rating. Similarly, ampere-rated fuses were used.

2. If the input voltage is low in two phases, loads L1 and L2 may also be connected to the third phase. In that situation, a high-rating fuse will be required at the input of the third phase which is taking the total load. ●